

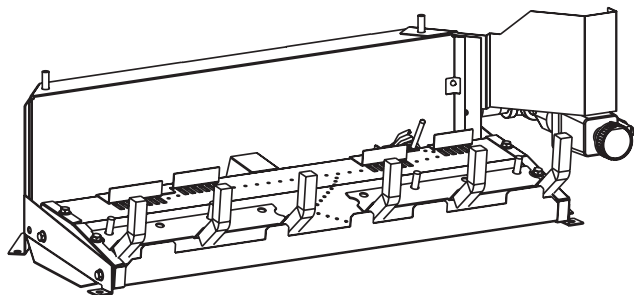

# INSTALLATION INSTRUCTIONS AND OWNER'S MANUAL

## The *White Mountain* Vented Slope Glaze Burner



**WARNING:** If the information in these instructions are not followed exactly, a fire or explosion may result causing property damage, personal injury or loss of life.

- Do not store or use gasoline or other flammable vapors and liquids in the vicinity of this or any other appliance.
- **WHAT TO DO IF YOU SMELL GAS**
  - Do not try to light any appliance.
  - Do not touch any electrical switch; do not use any phone in your building.
  - Immediately call your gas supplier from a neighbor's phone. Follow the gas supplier's instructions.
  - If you cannot reach your gas supplier, call the fire department.
- Installation and service must be performed by a qualified installer, service agency or the gas supplier.

**WARNING:** This log set is to be installed only in a solid-fuel burning fireplace with a working flue constructed of non-combustible material. The vent damper must also have a damper clamp attached to it to keep the damper from accidentally closing during operation.

**WARNING:** If not installed, operated and maintained in accordance with the manufacturer's instructions, this product could expose you to substances in fuel or from fuel combustion which can cause death or serious illness.

### VENTED DECORATIVE LOG SET FOR INSTALLATION IN SOLID-FUEL BURNING FIREPLACES

#### MODELS

VSM-18-1      VSR-18-2  
VSM-24-1      VSR-24-2  
VSM-30-1      VSR-30-2



**Installer:** Leave this manual with the appliance.  
**Consumer:** Retain this manual for future reference.

**AVERTISSEMENT:** Assurez vous de bien suivre les instructions données dans cette notice pour réduire au minimum le risque d'incendie ou d'explosion ou pour éviter tout dommage matériel, toute blessure ou la mort.

- Ne pas entreposer ni utiliser d'essence ni d'autres vapeurs ou liquides inflammables dans le voisinage de cet appareil ou de tout autre appareil.
- **QUE FAIRE SI VOUS SENTEZ UNE ODEUR DE GAZ:**
  - Ne pas tenter d'allumer d'appareil.
  - Ne touchez à aucun interrupteur. Ne pas vous servir des téléphones se trouvant dans le bâtiment où vous vous trouvez.
  - Appelez immédiatement votre fournisseur de gaz depuis un voisin. Suivez les instructions du fournisseur.
  - Si vous ne pouvez rejoindre le fournisseur de gaz, appelez le service des incendies.
- L'installation et l'entretien doivent être assurés par un installateur ou un service d'entretien qualifié ou par le fournisseur de gaz.

# TABLE OF CONTENTS

Section	Page
Important Safety Information .....	3
Safety Information for Users of LP Gas.....	4
Introduction.....	5
General Information.....	5-6
Fireplace Preparation .....	6-7
Before Fully Installing the Appliance .....	7
Gas Supply .....	8
Placement of Glowing Embers and Lava Rock .....	9
Operation Instructions/Flame Appearance .....	9
VSM-(18, 24, 30) Lighting Instructions .....	10
VSR-(18, 24, 30) Lighting Instructions .....	11
Pilot and Main Burner Flame Characteristics .....	12
Wiring .....	13
Cleaning and Servicing .....	13
Troubleshooting.....	14
Parts List.....	15
Parts View .....	16
Propane (LP) Gas Conversion Instructions.....	17
Natural Gas Conversion Instructions.....	18
Master Parts Distributor List .....	19
How To Order Repair Parts .....	19

**⚠ CAUTION: If logs or branches are damaged do not use.**

A certain amount of sooting will occur which enhances the realistic look of the logs and branches. If an excessive amount of sooting does occur you can use a gas log cleaner to remove the soot build-up or lightly brush off the soot build-up with a soft bristle brush taking care not to damage the logs and branches.

# IMPORTANT SAFETY INFORMATION

Installer: Please leave these instructions with the owner for future reference.

This unit complies with ANSI Z21.60 and CGA 2.26 Decorative Gas Appliances For Installation In Solid Fuel Burning Fireplaces. Do not burn wood or solid fuels in a fireplace where a decorative gas log set is installed. This appliance is for installation only in a solid fuel burning fireplace, masonry fireplace or manufactured fireplace.

**⚠ WARNING:** Any modification to this gas log set or to controls can be dangerous. Improper installation or use of the gas log set can cause serious injury or death from fire, burns, explosion or carbon monoxide poisoning.

1. Please follow all local codes regarding installation, combustion and ventilation air or in the absence of local codes follow the National Fuel Gas Code ANSI Z223.1 (U.S. installation), or CAN/CGA-B149, Installation Code (Canada installation).

2. Proper installation, burner pan location and log placement is important to achieve optimum look and performance of your gas log set. The logs have been designed for easy location and placement on the grate and must be followed for proper operation.
3. Do not operate this log set with glass doors in the closed position. A fireplace screen must be in place when the log set is burning. Adequate combustion air must be provided for proper venting. All flames should go up and out the top of the firebox into the flue vent. If any flames float or curl forward into the room **do not operate appliance**. Check for an open flue and adequate combustion air into the room. A damper clamp must be installed on the firebox damper to maintain an open flue vent condition.
4. Young children must be carefully supervised when they are in the same room as the gas log while in operation. Do not place stockings, clothing or any flammable material above or near the fireplace.
5. Do not substitute or use materials other than those supplied for use with the log set.

## DO NOT OPERATE THIS GAS LOG SET WITH GLASS DOORS CLOSED.

**⚠ DANGER:** Indicates a hazardous situation which, if not avoided, will result in death or serious injury.

**⚠ WARNING:** Indicates a hazardous situation which, if not avoided, could result in death or serious injury.

**⚠ CAUTION:** Indicates a hazardous situation which, if not avoided, could result in minor or moderate injury.

**NOTICE:** Addresses practices not related to personal injury.

- Due to high temperatures the appliance should be located out of traffic and away from furniture and draperies.
- Children and adults should be alerted to the hazards of high surface temperatures and should stay away to avoid burns or clothing ignition.
- Young children should be carefully supervised when they are in the same room as the appliance.
- Clothing or other flammable material should not be placed on or near the appliance.
- Do not place trash or other articles on the log set during operation.
- During manufacturing, fabricating and shipping, various components of this appliance are treated with certain oils, films or bonding agents. These bonding agents are not harmful but may produce annoying smoke and smells as they are burned off during initial operation of the appliance. This is a normal temporary occurrence. A window should be opened during the initial bake out period.
- Keep burner and control compartment clean.
- **⚠ WARNING:** Before installing in a solid fuel burning fireplace, the chimney flue and firebox must be cleaned of soot, creosote, ashes and loose paint by a qualified chimney cleaner.
- **⚠ WARNING:** Do not allow fans to blow directly into the fireplace. Avoid any drafts that alter burner flame patterns.

- **⚠ WARNING:** Do not use a blower insert, heat exchanger insert or other accessory not approved for use with this appliance.
- Installation and repair should be done by a **QUALIFIED SERVICE PERSON**. The appliance should be inspected before use and at least annually by a qualified service person. More frequent cleaning may be required due to excessive lint from carpeting, bedding materials, etc. It is imperative that control compartments, burners and circulating air passageways of the appliance be kept clean.
- **DO NOT** put anything around the fireplace that will obstruct the flow of ventilation air.
- **DO** keep the appliance area clear and free from combustible material, gasoline and other flammable vapors and liquids.
- A yearly examination and cleaning of the venting system of the solid-fuel burning fireplace must be performed by a qualified agency.
- **DO** make a periodic visual check of pilot and burners. Clean and replace damaged parts.
- **DO NOT** use this appliance if any part has been under water. Immediately call a qualified service technician to inspect the appliance and to replace any part of the control system and any gas control which has been under water.
- Ne pas se servir de cet appareil s'il a été plongé dans l'eau, complètement ou en partie. Appeler un technicien qualifié pour inspecter l'appareil et remplacer toute partie du système de contrôle et toute commande qui ont été plongés dans l'eau.

# SAFETY INFORMATION FOR USERS OF LP-GAS

Propane (LP-Gas) is a flammable gas which can cause fires and explosions. In its natural state, propane is odorless and colorless. You may not know all the following safety precautions which can protect both you and your family from an accident. Read them carefully now, then review them point by

point with the members of your household. Someday when there may not be a minute to lose, everyone's safety will depend on knowing exactly what to do. If, after reading the following information, you feel you still need more information, please contact your gas supplier.

## LP-GAS WARNING ODOR

**If a gas leak happens, you should be able to smell the gas because of the odorant put in the LP-Gas. That's your signal to go into immediate action!**

- Do not operate electric switches, light matches, use your phone. Do not do anything that could ignite the gas.
- Get everyone out of the building, vehicle, trailer, or area. Do that IMMEDIATELY.
- Close all gas tank or cylinder supply valves.
- LP-Gas is heavier than air and may settle in low areas such as basements. When you have reason to suspect a gas leak, keep out of basements and other low areas. Stay out until firefighters declare them to be safe.
- Use your neighbor's phone and call a trained LP-Gas service

person and the fire department. Even though you may not continue to smell gas, do not turn on the gas again. Do not re-enter the building, vehicle, trailer, or area.

- **Finally**, let the service man and firefighters check for escaped gas. Have them air out the area before you return. Properly trained LP-Gas service people should repair the leak, then check and relight the gas appliance for you.

## NO ODOR DETECTED - ODOR FADE

**Some people cannot smell well. Some people cannot smell the odor of the chemical put into the gas. You must find out if you can smell the odorant in propane.** Smoking can decrease your ability to smell. Being around an odor for a time can affect your sensitivity or ability to detect that odor. Sometimes other odors in the area mask the gas odor. People may not smell the gas odor or their minds are on something else. Thinking about smelling a gas odor can make it easier to smell.

**The odorant in LP-gas is colorless, and it can fade under some circumstances.** For example, if there is an underground leak, the movement of the gas through soil can filter the odorant. Odorants in LP-Gas also are subject to oxidation. This fading can occur if there is rust inside the storage tank or in iron gas pipes.

The odorant in escaped gas can adsorb or absorb onto or into walls, masonry and other materials and fabrics in a room. That will take some of the odorant out of the gas, reducing its odor intensity.

LP-Gas may stratify in a closed area, and the odor intensity could vary at different levels. Since it is heavier than air, there may be more odor at lower levels. Always be sensitive to the slightest gas odor. If you detect any odor, treat it as a serious leak. Immediately go into action as instructed earlier.

## SOME POINTS TO REMEMBER

- **Learn to recognize the odor of LP-gas.** Your local LP-Gas Dealer can give you a "Scratch and Sniff" pamphlet. Use it to find out what the propane odor smells like. If you suspect that your LP-Gas has a weak or abnormal odor, call your LP-Gas Dealer.
- If you are not qualified, do not light pilot lights, perform service, or make adjustments to appliances on the LP-Gas system. If you are qualified, consciously think about the odor of LP-Gas prior to and while lighting pilot lights or performing service or making adjustments.
- Sometimes a basement or a closed-up house has a musty smell that can cover up the LP-Gas odor. Do not try to light pilot lights, perform service, or make adjustments in an area where the conditions are such that you may not detect the odor if there has been a leak of LP-Gas.
- Odor fade, due to oxidation by rust or adsorption on walls of new cylinders and tanks, is possible. Therefore, people should be particularly alert and careful when new tanks or cylinders are placed in service. Odor fade can occur in new tanks, or reinstalled old tanks, if they are filled and allowed to set too long before refilling. Cylinders and tanks which have been out of service for a time may develop internal rust which will

cause odor fade. If such conditions are suspected to exist, a periodic sniff test of the gas is advisable. **If you have any question about the gas odor, call your LP-gas dealer. A periodic sniff test of the LP-gas is a good safety measure under any condition.**

- If, at any time, you do not smell the LP-Gas odorant and you think you should, assume you have a leak. Then take the same immediate action recommended above for the occasion when you do detect the odorized LP-Gas.
- If you experience a complete "gas out," (the container is under no vapor pressure), turn the tank valve off immediately. If the container valve is left on, the container may draw in some air through openings such as pilot light orifices. If this occurs, some new internal rusting could occur. If the valve is left open, then treat the container as a new tank. Always be sure your container is under vapor pressure by turning it off at the container before it goes completely empty or having it refilled before it is completely empty.

# INTRODUCTION

## Product Components

- Burner Pan Assembly
  - "M" model includes manual gas valve, regulator and safety pilot.
  - "R" model includes millivolt valve and safety thermopile generator and on/off switch. A remote control or wall switch accessory is available as an option for this model.
- 1 Bag of Glowing Embers (Rock Wool)
- 1 Damper Clamp
- 2 Bags Decorative Rock

Always consult your local Building Department regarding regulations, codes or ordinances which apply to the installation of a vented decorative gas log set in a solid-fuel burning fireplace.

This appliance is only for use with the type of gas indicated on the rating plate.

## Instructions to Installer

1. Installer must leave instruction manual with owner after installation.
2. Installer must have owner fill out and mail warranty card supplied with the fireplace.
3. Installer should show owner how to start and operate the fireplace.

### ⚠ WARNING

ANY CHANGE TO THIS APPLIANCE OR ITS CONTROLS CAN BE DANGEROUS.

**Improper installation or use of the appliance can cause serious injury or death from fire, burns, explosion or carbon monoxide poisoning.**

# GENERAL INFORMATION

This series is design certified in accordance with American National Standard/CSA Standard Z21.60 and CGA 2.26, respectively, by the Canadian Standards Association as a Vented Decorative Appliance and should be installed according to these instructions.

**Any alteration of the original design, installed other than as shown in these instructions or use with a type of gas not shown on the rating plate is the responsibility of the person and company making the change.**

## Important

All correspondence should refer to complete Model Number, Serial Number and type of gas.

**Notice:** During initial use of the logs and branches you will detect an odor as the logs and branches are cured.

## Specifications (Figure 1)

Model	Input Btuh	** Reduced Input BTUH	Minimum Front Width	Depth	Height
VSM-18*	65,000	40,000	32"	15"	22"
VSM-24*	75,000	50,000	34"	15"	22"
VSM-30*	75,000	60,000	38"	15"	22"
VSR-18†	65,000	40,000	28"	15"	22"
VSR-24†	75,000	50,000	30"	15"	22"
VSR-30†	75,000	60,000	34"	15"	22"

Model	Input KW/H	**Reduced Input BTUH	Minimum Front Width (cm)	Depth (cm)	Height (cm)
VSM-18*	19.0	11.7	81.3	38.1	55.8
VSM-24*	21.9	14.6	86.4	38.1	55.8
VSM-30*	21.9	17.5	96.5	38.1	55.8
VSR-18†	19.0	11.7	71.1	38.1	55.8
VSR-24†	21.9	14.6	76.2	38.1	55.8
VSR-30†	21.9	17.5	86.4	38.1	55.8

\* M Denotes manual gas valve

† R Denotes millivolt gas valve

\*\* Attention: An additional main burner orifice is provided in instruction package envelope to reduce the input of the burner assembly.

Gas Inlet VSM Models	3/8" (9.5mm)
Gas Inlet VSR Models	3/8" (9.5mm)
<b>Accessories for VSM and VSR Models</b>	
Embers Kit	EK-1
<b>Accessories for VSR Models</b>	
Battery Operated Remote Control	FRBC
Electric Remote	FREC
Wall Switch	FWS

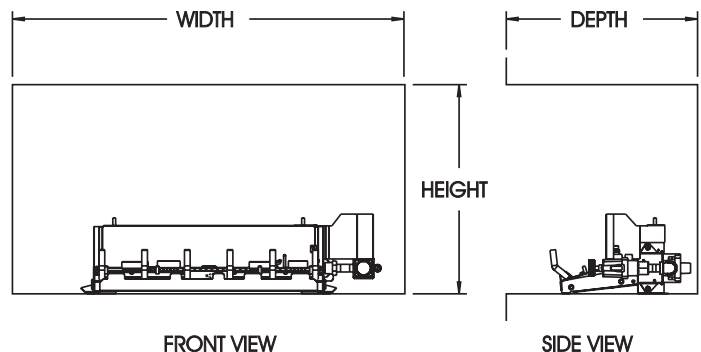

Figure 1

# GENERAL INFORMATION (continued)

## Qualified Installing Agency

Installation and replacement of gas piping, gas utilization equipment or accessories and repair and servicing of equipment shall be performed only by a qualified agency. The term "qualified agency" means any individual, firm, corporation or company which either in person or through a representative is engaged in and is responsible for (a) the installation or replacement of gas piping or (b) the connection, installation, repair or servicing of equipment, who is experienced in such work, familiar with all precautions required and has complied with all the requirements of the authority having jurisdiction.

**State of Massachusetts:** The installation must be made by a licensed plumber or gas fitter in the Commonwealth of Massachusetts.

The installation and the provisions for combustion and ventilation air must conform with the *National Fuel Gas Code, ANSI Z223.1/ NFPA54\** Canadian Installation Code *CAN/CGA B149*.

*\*Available from the American National Standards Institute, Inc. 11 West 42nd St., New York, N.Y. 10018.*

## High Altitude Installation

When installing this unit at an elevation above 2000 feet (in the United States) it may be necessary to decrease the input rating by changing the existing burner orifice to a smaller size. Generally, input should be reduced 4 percent for each 1000 feet above sea level. However, if the heating value of the gas has been reduced, this general rule may not apply. Check with local gas utility for proper orifice size identification.

For Canadian high altitude applications, this appliance is suitable for installation at elevations between 0 feet (0m) and 4,500 (1,370m) without change.

When installing this unit at an elevation above 4500 feet (1,370m) (in Canada), check with local authorities.

Consult your local gas utility for assistance in determining the proper orifice for location.

# FIREPLACE PREPARATION

- Turn off gas supply to fireplace or firebox.
- Have the fireplace floor and chimney professionally cleaned to remove ashes, soot, creosote or other obstructions. Have this cleaning performed annually after installation.
- Seal any fresh air vents or ash clean-out doors located on floor or wall of fireplace. If not, drafting may cause pilot outage or sooting. Use a heat-resistant sealant. Do not seal chimney flue damper.

## Installing Damper Clamp (Figure 2)

Remove all ashes or other debris from the fireplace. If the fireplace is equipped with an ash dump be sure to seal the door with furnace cement or high temperature silicone. Be sure to check the damper for proper operation and verify that the flue passageway is open. Attach damper clamp to the vent damper and tighten hold down bolt.

Place the clamp over the lip of the damper and tighten the hold down bolt until the clamp is securely attached to the damper. This will prevent the damper from accidentally closing.

State of Massachusetts requirement for installation of vented decorative appliance in a vented fireplace is the following:

In the Commonwealth of Massachusetts vent free products are not approved.

A vented decorative gas appliance must be installed in a vented fireplace only in the state of Massachusetts. The vent damper must be removed or welded permanently open.

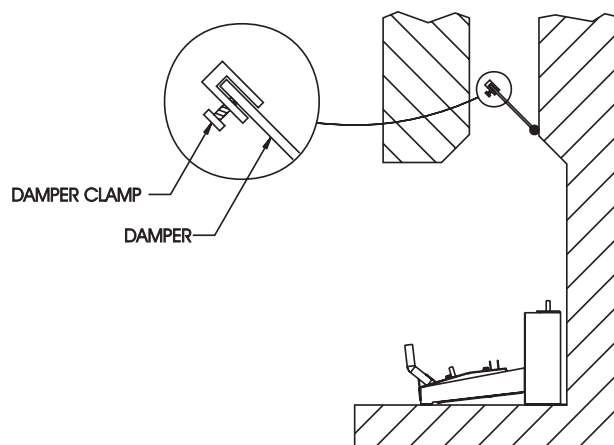

TYPICAL FIREPLACE

Figure 2

**FOR FACTORY BUILT FIREPLACES**  
**FREE OPENING AREA OF CHIMNEY DAMPER FOR VENTING COMBUSTION PRODUCTS FROM DECORATIVE APPLIANCES FOR INSTALLATION IN SOLID FUEL BURNING FIREPLACES.**

	Appliance Input Rate (kBtu/hr)						
	20	30	40	50	60	70	80
Chimney Height* (ft)	Minimum Opening** (sq. in.)						
10	11.3	16.6	22.1	28.3	35.3	44.2	-
15	8.6	12.6	17.3	21.2	26.4	32.2	31.2
20	7.5	10.8	14.5	18.1	22.1	26.4	31.2
25	6.6	9.6	12.6	15.9	18.1	22.9	27.3
30	6.2	9.1	11.3	14.5	17.3	20.4	24.6
35	5.7	8.0	10.8	13.2	15.9	18.9	22.1
40	5.3	7.5	10.2	12.6	15.2	18.1	20.4

	Appliance Input Rate KW/HR						
	5.9	8.8	11.7	14.6	17.6	20.5	23.4
Chimney Height* (m)	Minimum Opening** (sq. in.)						
3.05	72.9	107.1	142.6	182.6	227.8	285.2	-
4.57	55.5	81.3	111.6	136.8	170.3	207.8	248.4
6.10	48.4	69.7	93.6	116.8	142.6	170.3	201.3
7.62	42.6	61.9	81.3	102.6	116.8	147.8	176.1
9.14	40.0	58.7	72.9	93.6	111.6	131.6	158.7
10.67	36.8	51.6	69.7	85.2	102.6	121.9	142.6
12.19	34.2	48.4	65.8	81.3	98.1	116.8	131.6

\* Height is from hearth to top of chimney and the minimum height is 10 feet (3.05m).

\*\* Chart shows minimum opening (sq. in.) (cm<sup>2</sup>) for given height and input rate.

**FOR MASONRY BUILT FIREPLACES**  
**FREE OPENING AREA OF CHIMNEY DAMPER FOR VENTING COMBUSTION PRODUCTS FROM DECORATIVE APPLIANCES FOR INSTALLATION IN SOLID FUEL BURNING FIREPLACES.**

	Appliance Input Rate (kBtu/hr)						
	20	30	40	50	60	70	80
Chimney Height* (ft)	Minimum Opening** (sq. in.)						
6	17.6	25.7	33.8	41.7	49.2	56.6	64.0
8	16.5	23.7	31.2	38.7	45.5	52.4	59.7
10	15.1	21.7	28.7	35.2	41.7	48.2	54.3
15	14.1	19.9	26.1	32.0	37.7	43.2	48.8
20	12.9	18.5	23.7	28.8	34.3	39.8	44.4
30	12.2	16.9	21.6	26.5	31.2	35.9	40.3

	Appliance Input Rate KW/HR						
	5.9	8.8	11.7	14.6	17.6	20.5	23.4
Chimney Height* (m)	Minimum Opening** (sq. in.)						
1.83	113.6	165.8	218.1	269.0	317.4	365.2	412.9
2.44	106.5	152.9	201.3	249.7	293.6	338.1	385.2
3.05	97.4	140.0	185.2	227.1	269.0	311.0	350.3
4.57	91.0	128.4	168.4	206.5	243.2	278.7	314.8
6.10	83.2	119.4	152.9	185.8	221.3	256.8	286.5
9.14	78.7	109.0	139.4	171.0	201.3	231.6	260.0

\* Height is from hearth to top of chimney and the minimum height is 6 feet (1.83m).

\*\* Chart shows minimum opening (sq. in.) (cm<sup>2</sup>) for given height and input rate.

## BEFORE FULLY INSTALLING THE APPLIANCE

Before installing in a solid fuel burning fireplace, the chimney flue and firebox must be cleaned of soot, creosote, ashes and loose paint by a qualified chimney cleaner.

**You must secure the gas log heater to the fireplace floor. If not, the entire unit may move when you adjust the controls. Movement of unit may cause shifting of the gas logs which leads to sooting and improper burning. Grate movement could cause a gas leak.**

**Special care is required if you are installing the unit into a sunken fireplace. You must raise the fireplace floor to allow access to gas log controls. This will insure adequate air flow and guard against sooting. Raise the fireplace floor using noncombustible materials.**

- Center the gas log in the fireplace or firebox. The grates must clear the fireplace or firebox screen.
- An anchor hole is provided in the two bottom side members of the grate frame. After centering the grate correctly, mark the hole positions on the fireplace/firebox floor. Drill two (2) 5/32" diameter holes approximately 1-1/2" deep for masonry screws or 1/8" hole for sheet metal screws.

- Anchor the grate to the fireplace/firebox floor using the screws provided.

**Proper installation of the grate is essential to prevent any movement of the gas logs and controls during operation.**

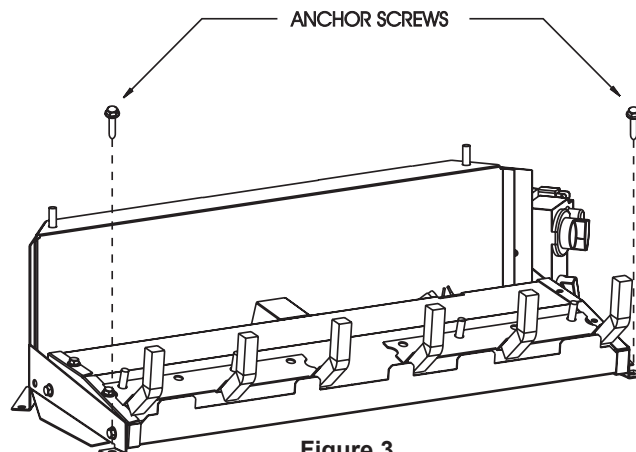

Figure 3

# GAS SUPPLY

Check all local codes for requirements, especially for the size and type of gas supply line required.

**Recommended Gas Pipe Diameter**

Pipe Length	Schedule 40 Pipe Inside Diameter		Tubing, Type L Outside Diameter	
	Nat.	L.P.	Nat.	L.P.
0-10 feet 0-3 meters	1/2"	3/8"	1/2"	3/8"
10-40 feet 4-12 meters	1/2"	1/2"	5/8"	1/2"
40-100 feet 13-30 meters	1/2"	1/2"	3/4"	1/2"
100-150 feet 31-46 meters	3/4"	1/2"	7/8"	3/4"

**NOTICE:** Never use plastic pipe. Check to confirm whether your local codes allow copper tubing or galvanized.

**NOTICE:** Since some municipalities have additional local codes, it is always best to consult your local authority and installation code.

### Installing a New Main Gas Cock

Each appliance should have its own manual gas cock.

In the state of Massachusetts the gas cock must be a T handle type.

A manual main gas cock should be located in the vicinity of the unit. Where none exists, or where its size or location is not adequate, contact your local authorized installer for installation or relocation.

Compounds used on threaded joints of gas piping shall be resistant to the action of liquefied petroleum gases. The gas lines must be checked for leaks by the installer. This should be done with a soap solution watching for bubbles on all exposed connections, and if unexposed, a pressure test should be made.

**Never use an exposed flame to check for leaks. Appliance must be disconnected from piping at inlet of control valve and pipe capped or plugged for pressure test. Never pressure test with appliance connected; control valve will sustain damage!**

A gas valve and ground joint union should be installed in the gas line upstream of the gas control to aid in servicing. It is required by the National Fuel Gas Code that a drip line be installed near the gas inlet. This should consist of a vertical length of pipe tee connected into the gas line that is capped on the bottom in which condensation and foreign particles may collect.

The use of the following gas connectors is recommended:

- ANS Z21.24 Appliance Connectors of Corrugated Metal Tubing and Fittings
- ANS Z21.45 Assembled Flexible Appliance Connectors of Other Than All-Metal Construction

The above connectors may be used if acceptable by the authority having jurisdiction. The state of Massachusetts requires that a flexible appliance connector cannot exceed three feet in length.

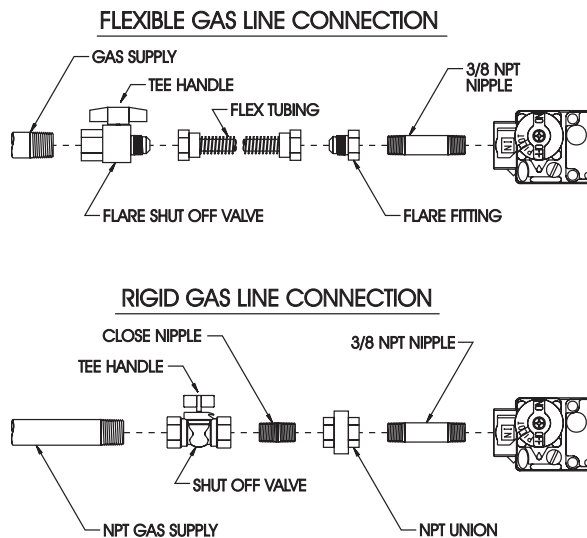

**Figure 4**

### Pressure Testing of the Gas Supply System

1. To check the inlet pressure to the gas valve, a 1/8" (3.175mm) N.P.T. plugged tapping, accessible for test gauge connection, must be placed immediately upstream of the gas supply connection to the appliance.
2. The appliance and its individual shutoff valve must be disconnected from the gas supply piping system during any pressure testing of that system at test pressures in excess of 1/2 psig (3.5 kPa).
3. The appliance must be isolated from the gas supply piping system by closing its individual manual shutoff valve during any pressure testing of the gas supply piping system at test pressures equal to or less than 1/2 psig (3.5 kPa).

**Attention!** If one of the procedures results in pressures in excess of 1/2 psig (14" w.c.) (3.5 kPa) on the appliance gas valve, it will result in a hazardous condition.

### Checking Manifold Pressure

**VSR** Natural gas models will have a manifold pressure of approximately 3.5" w.c. (.871kPa) at the pressure regulator outlet with the inlet pressure to the pressure regulator from a minimum of 4.5" w.c. (1.120kPa) for the purpose of input adjustment to a maximum of 10.5" w.c. (2.615kPa). **VSM** Natural gas models will have a manifold pressure of approximately 4.5" w.c. (1.12kPa) at the pressure regulator outlet with the inlet pressure to the pressure regulator from a minimum of 7.0" w.c. (1.74kPa) for the purpose of input adjustment to a maximum of 10.5" w.c. (2.615kPa). **VSR and VSM** Propane gas models will have a manifold pressure approximately 10.0" w.c. (2.49kPa) at the pressure regulator outlet with the inlet pressure to the pressure regulator from a minimum of 11.0" w.c. (2.739kPa) for the purpose of input adjustment to a maximum of 13.0" w.c. (3.237kPa).

### VSM

**NOTICE:** A test gage connection is located downstream of the gas appliance pressure regulator for measuring gas pressure. The connection is a 1/8 inch 3mm) N.P.T. plugged tapping.

### VSR

**NOTICE:** The gas control is equipped with a captured screw type pressure test point, therefore it is not necessary to provide a 1/8" test point up stream of the control.

# PLACEMENT OF GLOWING EMBERS AND LAVA ROCK

Placement of the glowing embers (rock wool) is very individual and light coverage of the areas indicated will provide your best effects. We recommend separation of the rock wool by hand and make your coverage as light and fluffy as possible.

Place just enough embers on the burner to obtain the glow and a gold, yellow flame.

Do not place embers (rock wool) over large ports in rear portion of burner.

Rock wool should **not** be placed in the area of the pilot assembly.

## Placing Lava Rock in Front of Burner on Fireplace Floor

Spread lava rocks on fireplace floor in front of the burner pan. The lava rocks are for decorative effect and are not required for fireplace operation.

**ATTENTION:** DO NOT PLACE LAVA ROCKS ON BURNER, LOGS OR ROCK WOOL. THE LAVA ROCKS SHOULD ONLY BE PLACED ON THE FIREPLACE FLOOR.

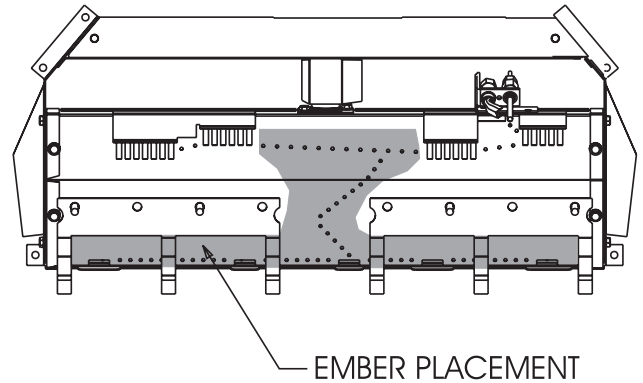

Figure 5

# OPERATION INSTRUCTIONS/FLAME APPEARANCE

Flames from the pilot (right back side of the pan burner) as well as the main flame should be visually checked as the log set is installed.

In normal operation at full rate after 10 to 15 minutes, the flame appearance should be sets of yellow flames.

**NOTICE:** all flames will be random by design, flame height will go up and down.

Avoid any drafts that alter burner flame patterns. Do not allow fans to blow directly into fireplace. Do not place a blower inside the burner area of the firebox. Ceiling fans may create drafts that alter flame patterns. Sooting and improper burning will result.

During manufacturing, fabricating and shipping, various components of this appliance are treated with certain oils, films or bonding agents. These chemicals are not harmful, but may produce annoying smoke and smells as they are burned off during the initial operation of the appliance, possibly causing headaches or eye or lung irritation. This is a normal and temporary occurrence.

The initial break-in operation should last 2-3 hours with the burner at the highest setting. Provide maximum ventilation by opening windows or doors to allow odors to dissipate. Any odors remaining after this initial break-in will be slight and will disappear with continued use.

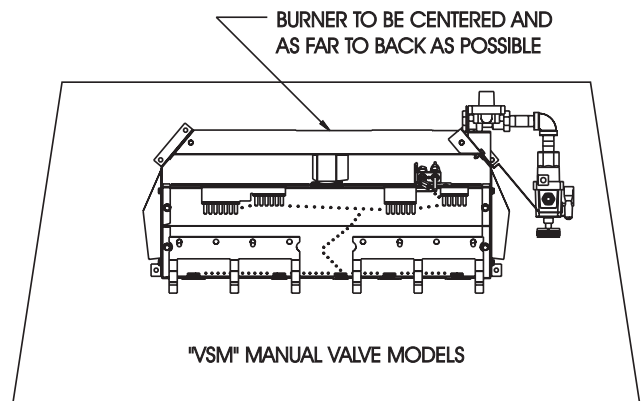

Manual - Figure 6

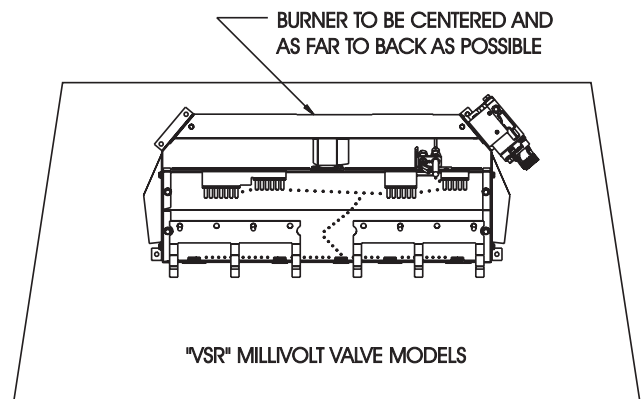

Millivolt - Figure 7

# VSM-(18, 24, 30) LIGHTING INSTRUCTIONS

## FOR YOUR SAFETY READ BEFORE LIGHTING

**⚠ WARNING:** If you do not follow these instructions exactly, a fire or explosion may result causing property damage, personal injury or loss of life.

- A. This appliance has a pilot which must be lighted by hand. When lighting the pilot, follow these instructions exactly.
- B. **BEFORE LIGHTING** smell all around the appliance area for gas. Be sure to smell next to the floor because some gas is heavier than air and will settle on the floor.

### WHAT TO DO IF YOU SMELL GAS

- Do not try to light any appliance.
- Do not touch any electrical switch; do not use any phone in your building.
- Immediately call your gas supplier from a neighbor's phone. Follow the gas supplier's instructions.
- If you cannot reach your gas supplier, call the fire

department.

- C. Use only your hand to push in or turn the gas control knob. Never use tools. If the knob will not push in or turn by hand, don't try to repair it; call a qualified service technician. Force or attempted repair may result in a fire or explosion.
- D. Do not use this appliance if any part has been under water. Immediately call a qualified service technician to inspect the appliance and to replace any part of the control system and any gas control which has been under water.

## LIGHTING INSTRUCTIONS

### ⚠ WARNING

- Any glass doors shall be opened when the appliance is in operation.
- A fireplace screen must be in place when the appliance is operating and, unless other provisions for combustion air are provided, the screen shall have an opening(s) for introduction of combustion air.

1. **STOP!** Read the safety information above.
2. Push in manual gas control knob slightly and turn clockwise  to "OFF". Do not force.

**NOTE:** Knob cannot be turned from "PILOT" to "OFF" unless knob is pushed in slightly. Do not force.

GAS CONTROL  
KNOB SHOWN IN  
"OFF" POSITION

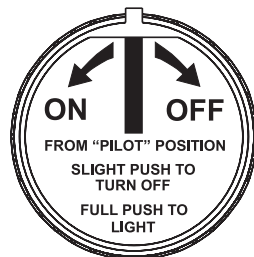

3. Wait ten (10) minutes to clear out any gas. Then smell for gas, including near the floor. If you smell gas, **STOP!** Follow "B" in the safety information above. If you don't smell gas, go to the next step.
4. Find pilot - follow metal tube from gas control. The pilot is in front of middle log on the right side.
5. Turn manual gas control knob counterclockwise  to "PILOT."
6. Push in control knob all the way and hold in. Im-

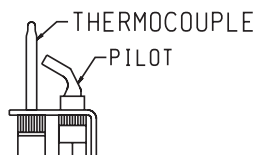

mediately light the pilot with a match and the lighter rod that is provided with the burner. Continue to hold the control knob in for about one (1) minute after the pilot is lit. Release knob and it will pop back up. Pilot should remain lit. If it goes out, repeat steps 2 through 6.

- If knob does not pop up when released, stop and immediately call a qualified service technician or gas supplier.
- If the pilot will not stay lit after several tries, turn the gas control knob to "OFF" and call your service technician or gas supplier.

7. Turn manual gas control knob counterclockwise  to "ON."

## TO TURN OFF GAS TO APPLIANCE

1. Push in gas control knob slightly and turn clockwise  to "OFF." Do not force.

# VSR-(18, 24, 30) LIGHTING INSTRUCTIONS

## FOR YOUR SAFETY READ BEFORE LIGHTING



**▲ WARNING:** If you do not follow these instructions exactly, a fire or explosion may result causing property damage, personal injury or loss of life.

- A. This appliance has a pilot which must be lighted by hand. When lighting the pilot, follow these instructions exactly.
- B. **BEFORE LIGHTING** smell all around the appliance area for gas. Be sure to smell next to the floor because some gas is heavier than air and will settle on the floor.
- WHAT TO DO IF YOU SMELL GAS**
- Do not try to light any appliance.
  - Do not touch any electrical switch; do not use any phone in your building.
  - Immediately call your gas supplier from a neighbor's phone. Follow the gas supplier's instructions.
  - If you cannot reach your gas supplier, call the fire department.
- C. Use only your hand to push in or turn the gas control knob. Never use tools. If the knob will not push in or turn by hand, don't try to repair it; call a qualified service technician. Force or attempted repair may result in a fire or explosion.
- D. Do not use this appliance if any part has been under water. Immediately call a qualified service technician to inspect the appliance and to replace any part of the control system and any gas control which has been under water.

## LIGHTING INSTRUCTIONS

**▲ WARNING**

- Any glass doors shall be opened when the appliance is in operation.
- A fireplace screen must be in place when the appliance is operating and, unless other provisions for combustion air are provided, the screen shall have an opening(s) for introduction of combustion air.

1. STOP! Read the safety information above.
2. Set the ON/OFF switch to "OFF."
3. Turn off all electric power to the appliance (if applicable).
4. Push in gas control knob slightly and turn clockwise  to "OFF."
5. Wait ten (10) minutes to clear out any gas. Then smell for gas, including near the floor. If you smell gas, STOP! follow "B" in the safety information above. If you do not smell gas, go to the next step.  
**NOTE:** Knob cannot be turned from "PILOT" to "OFF" unless knob is pushed in slightly. Do not force.
6. Find pilot - follow metal tube from gas control. The pilot is in front of the middle log on the right side.
7. Turn gas control knob counterclockwise  to "PILOT."

**GAS CONTROL KNOB SHOWN IN "OFF" POSITION.**

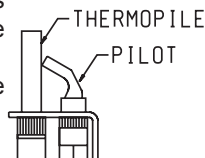
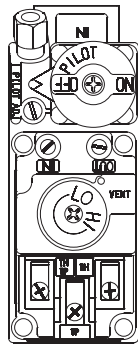

8. Push in control knob all the way and hold in. Immediately light the pilot with a match and lighter rod that is provided with the burner. Continue to hold the control knob in for about one (1) minute after the pilot is lit. Release knob, and it will pop back up. Pilot should remain lit. If it goes out, repeat steps 4 through 8.  
If knob does not pop up when released, stop and immediately call a qualified service technician or gas supplier.  
If the pilot will not stay lit after several tries, turn the gas control knob to "OFF" and call your service technician or gas supplier.
9. Turn gas control knob counter clockwise  to "ON."
10. Set the ON/OFF switch to "ON."

## TO TURN OFF GAS TO APPLIANCE

1. Set the ON/OFF switch to "OFF".
2. Push in gas control knob slightly and turn clockwise  to "OFF". Do not force.

# PILOT AND MAIN BURNER FLAME CHARACTERISTICS

## Pilot Flame Pattern (Figure 9)

Figure 8 shows a correct pilot flame pattern. The correct flame will be blue and will extend beyond the thermocouple/thermopile. The flame will surround the thermocouple/thermopile just below the tip. A slight yellow flame may occur where the pilot flame and main burner flame meet.

After use, cleaning of the pilot burner may be required for the proper flame. The pilot orifice can be cleaned with high pressure air or by placing under running water. Pilot orifice must be dry before replacement. Use a pipe cleaner to clean inside the pilot after the pilot orifice has been removed.

## To Remove Pilot Orifice

1. Disconnect the pilot supply line at the pilot burner.
2. Remove pilot orifice from pilot burner. It may be necessary to tap on pilot burner in order to remove the pilot orifice.

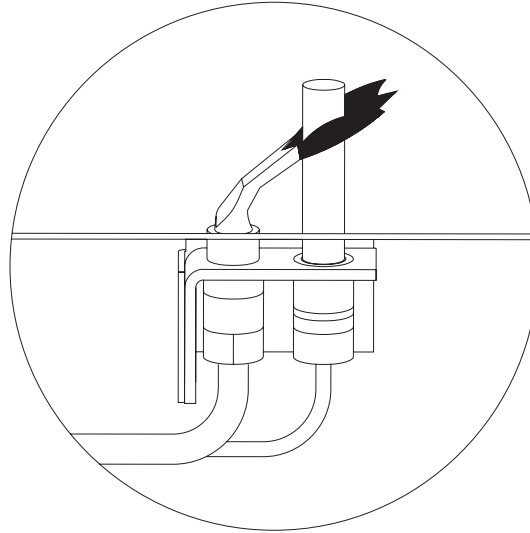

**Pilot Flame Pattern  
Figure 9**

If pilot flame pattern is incorrect

- See Troubleshooting, page 15

## Main Burner Flame Pattern

The main burner flame will be completely yellow.

## Main Burner Flame Ignition and Extinction

When the main burner is ignited it will take a few seconds for the full flame pattern to develop.

When the main burner is extinguished it will take a few seconds for the flames to disappear. It is normal to have the flames burn down near the rock wool, as the remaining gas is burned.

# WIRING

Thermostats are not approved on vented decorated appliances.

Label all wires prior to disconnection when servicing controls. Wiring errors can cause improper and dangerous operation. Verify proper operation after servicing.

VSR gas valve does not require 24 or 110 volts. See Figure 10 to provide optional wall switch or remote control.

It is important to use wire of a gauge proper for the length of the wire:

RECOMMENDED WIRE GAUGES	
Maximum Length	Wire Gauge
1' to 10'	18
10' to 25'	16
25' to 35'	14

Use the two leads (black wires) from **ON/OFF** switch to attach optional components.

### Check System Operation

Millivolt system and all individual components may be checked with a millivolt meter 0-1000 MV range.

### 750 Millivolt System

When you ignite the pilot, the thermocouple produces millivolts (electrical current) which energizes the magnet in the gas valve. After 30 seconds to 1 minute time period you can release the gas control knob and the pilot will stay ON. Allow your pilot flame to operate an additional one (1) to two (2) minutes before you turn the gas control knob from the PILOT position to the ON position. This time period allows the millivolts (electrical current) to buildup to a sufficient level allowing the gas control to operate properly.

### Millivolt Control

The valve regulator controls the burner pressure which should be checked at the pressure test point. Turn captured screw counter clockwise 2 or 3 turns and then place tubing to pressure gauge over test point (Use test point "A" closest to control knob). After taking pressure reading, be sure and turn captured screw clockwise firmly to re-seal. Do not over torque. Check for gas leaks.

### Remote Receiver -VSR-(18, 24, 30)

Use the following steps to place the **remote receiver** adjacent to the gas valve.

#### Attention:

1. The remote receiver **can not** be placed behind the gas valve and burner assembly.

2. When facing the appliance, the remote receiver must be placed in the **right** side firebox, toward the front.

**NOTICE:** Do not let remote control receiver come in contact with burner assembly.

Refer to remote control installation and operating instructions for more details on remote control.

VSR Wiring Diagram (Figure 10)

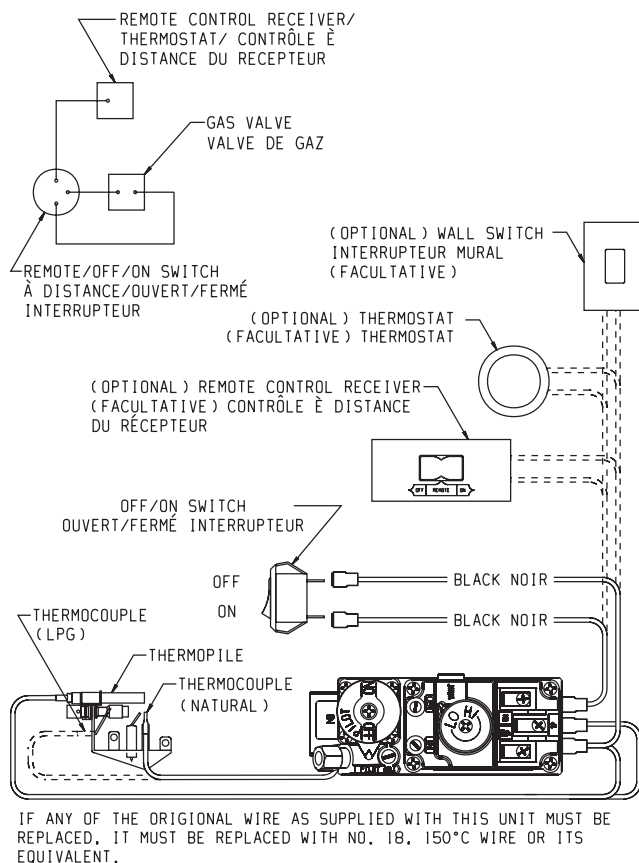

Figure 10

### VSR

**NOTICE: (Wiring harness located in envelope)**

Connect the 2 - 1/4" terminals onto the TH and TH/TP terminals on valve. Place decorative log to **right** of the gas valve and burner assembly. When connecting to remote receiver, cut off 1/4" terminals from wires attached to ON/OFF switch. Strip wires back about 1/4". Connect stripped ends into remote receiver.

# CLEANING AND SERVICING

Keep the control compartment, logs and burner area surrounding the logs clean.

**THE LOGS CAN GET VERY HOT— HANDLE ONLY WHEN COOL.**

Always keep the appliance area clear and free from combustible materials, gasoline, and other flammable vapors and liquids.

Never obstruct the flow of combustion and ventilation air. Keep the front of the appliance clear of all obstacles and materials.

### Inspecting Venting System

A vented fireplace venting system is designed and constructed to develop a positive flow adequate to remove flue gases to the outside atmosphere.

Any foreign objects in the venting system, may cause spillage of the flue gases into the room.

Periodic examination and/or cleaning of the venting system of the solid-fuel burning fireplace must be done by a qualified service person. Visually inspect the damper and flue area for excessive soot build-up. This soot (carbon) may be removed by brushing with a soft bristle brush.

# TROUBLESHOOTING

## SYMPTOMS-POSSIBLE CAUSES AND CORRECTIONS

### 1. Match will not light pilot.

- a. Main shut-off valve closed.
  - Make sure that the shut-off valve located on the pipe supplying gas to the fireplace is open.
- b. Air in the gas line.
  - Light a match, turn valve knob to "PILOT" position and depress, keep match near pilot burner until it lights.
- c. Valve knob in "OFF" position.
  - Turn valve knob to "PILOT" position and depress, keep match near pilot burner until it lights.
- d. Pilot orifice plugged up, not allowing gas to flow.
  - This repair requires tools and some degree of experience. Ask serviceman for assistance.
- e. No gas supply to the fireplace.
  - Check plumbing to see if gas fireplace has been hooked up to the gas supply line.
  - Propane tanks is empty.

### 2. Pilot will not stay lit after carefully following lighting instructions for VSR—Models.

- a. Defective pilot generator (thermopile), remote wall switch.
  - Check pilot flame. Must impinge on thermopile. Clean and or adjust pilot for maximum flame impingement on thermopile.
  - Be sure wire connections from thermopile at gas valve terminals are tight and thermopile is fully inserted into pilot bracket.
  - One of the wall switch wires may be grounded. Remove wall switch wires from valve terminals if pilot now stays lit, trace wall switch wiring for ground. May be grounded to appliance or gas supply.
  - Check thermopile with millivolt meter. Take reading at thermopile terminals of gas valve. Should read 325 millivolts minimum while holding valve knob depressed in pilot position and wall switch "Off." Replace faulty thermopile if reading is below specified minimum.
- b. Defective automatic valve operator — Turn valve knob to "On." Place wall switch to "On" millivolt meter should read greater than 100 M.V. If the reading is okay and the burner does not come on, replace the gas valve.
- c. Defective thermopile.
  - Check all connections and try.
  - If still not operating, disconnect lead between thermocouple switch and valve operator. Then disconnect lead to pilot magnet and connect to valve operator terminal (TP, TH). If pilot remains lit fault lies with thermocouple. Check that bulb is in proper location. If still not working replace thermocouple (see drawing in manual for additional information).

### 3. Pilot burning, no gas to burner, valve knob "On," wall switch "On."

- a. Wall switch or wires defective.
  - Check wall switch and wires for proper connections. Jumper wire cross terminals at wall switch, if burner comes on, replace defective wall switch. If okay, jumper wires cross wall switch wires at valve, if burner comes on, wires are faulty or connections are bad.
- b. Thermopile may not be generating sufficient millivoltage.
  - Replace.
- c. Plugged burner orifice.
  - Check burner orifice for debris and remove.

### 4. Pilot will not stay lit after carefully following lighting instructions for VSM—Models.

- a. Defective thermocouple.
  - Check that pilot flame impinges on thermocouple. Clean and/or adjust pilot for maximum flame impingement.
  - Ensure that the thermocouple connection at the gas valve is fully inserted and tight (hand tight plus 1/4 turn) faulty thermopile if reading is below specified minimum.
  - Disconnect the thermocouple from the valve, place one millivolt meter lead wire on the tip of the thermocouple and the other meter lead wire on the thermocouple copper lead. Start the pilot and hold the valve knob in. If the millivolt reading is less than 15 mv, replace the thermocouple.
- b. Defective valve.
  - If thermocouple is producing more than 15 millivolts, replace faulty valve.

### 5. Frequent pilot outage problem.

- a. Pilot flame may be too low or blowing (high) causing the pilot to drop out.
  - Clean and/or adjust flame for maximum flame impingement on thermopile or thermocouple.

### 6. Main burner flame is too low or too high.

- a. Check inlet supply pressure for "M" and "R" models.
- b. Check manifold pressure on gas valve for "R" models and inlet regulator on "M" models.

# PARTS LIST

INDEX NO.	PART NO.	DESCRIPTION	INDEX NO.	PART NO.	DESCRIPTION
<b>COMMON PARTS</b>			<b>VSM-18,24,30</b>		
1	15426	REAR LOG SUPPORT (18)	4	P-265	ORIFICE-LPG (18) (40,000 BTU)
1	15427	REAR LOG SUPPORT (24)	4	P-211	ORIFICE-NAT (18) (40,000 BTU)
1	15428	REAR LOG SUPPORT (30)	4	P-256	ORIFICE-LPG (18) (65,000 BTU)
2	11376	BURNER SUPPORT - LEFT	4	P-273	ORIFICE-NAT (18) (65,000 BTU)
3	P-271	ORIFICE FITTING	4	P-257	ORIFICE-LPG (24&30) (75,000 BTU)
5	R-5675	AIR SHUTTER-LPG	4	P-276	ORIFICE-LPG (24) (50,000 BTU)
5	R-5676	AIR SHUTTER-NAT	4	P-277	ORIFICE-NAT (24&30) (75,000 BTU)
6	15415	PILOT BRACKET	4	P-278	ORIFICE-NAT (24) (50,000 BTU)
7	R-7158	PILOT ASSEMBLY-NAT	4	P-181	ORIFICE-LPG (30) (60,000 BTU)
7	R-7157	PILOT ASSEMBLY-LPG	4	P-282	ORIFICE-NAT (30) (60,000 BTU)
8	14033	BURNER ASSEMBLY (18)	9	26291	BURNER SUPPORT - RIGHT
8	14035	BURNER ASSEMBLY (24)	11	R-7195	BRASS MALE CONNECTOR
8	14037	BURNER ASSEMBLY (30)	13	15413	REGULATOR MOUNTING BRACKET
<b>VSR-18,24,30</b>			14	R-7159	INLET REGULATOR - LPG
4	P-265	ORIFICE-LPG (18) (40,000 BTU)	14	R-7160	INLET REGULATOR - NAT
4	P-209	ORIFICE-NAT (18) (40,000 BTU)	15	P-133	NIPPLE 2"
4	P-256	ORIFICE-LPG (18) (65,000 BTU)	16	P-135	3/8" ELBOW
4	P-274	ORIFICE-NAT (18) (65,000 BTU)	17	P-239	NIPPLE 1 1/2"
4	P-257	ORIFICE-LPG (24&30) (75,000 BTU)	18	R-7278	GAS VALVE
4	P-276	ORIFICE-LPG (24) (50,000 BTU)	19	15494	COVER PLATE
4	P-279	ORIFICE-NAT (24&30) (75,000 BTU)	NS	15431	TUBING VALVE TO PILOT
4	P-280	ORIFICE-NAT (24) (50,000 BTU)	NS	15429	TUBING VALVE TO BURNER
4	P-181	ORIFICE-LPG (30) (60,000 BTU)	NS	15496	ROCK WOOL
4	P-283	ORIFICE-NAT (30) (60,000 BTU)	NS	11788	DECORATIVE ROCK
9	26291	BURNER SUPPORT - RIGHT	NS	R-2809	DAMPER CLAMP
10	26294	VALVE BRACKET	NS	R-734	LIGHTER ROD
11	R7195	BRASS MALE CONNECTOR	NS	R-2256	THERMOCOUPLE
12	R10408	GAS VALVE - LPG	NS - NOT SHOWN		
12	R10407	GAS VALVE - NAT			
NS	R1260	3/8" ELBOW 90 STREET			
NS	R-5910	SWITCH LOG ASSEMBLY			
NS	R-5699	WIRE HARNESS			
NS	R-5757	ON/OFF SWITCH			
NS	26282	TUBING VALVE TO PILOT			
NS	26283	TUBING VALVE TO BURNER			
NS	15496	ROCK WOOL			
NS	11788	DECORATIVE ROCK			
NS	R-2809	DAMPER CLAMP			
NS	R-734	LIGHTER ROD			
NS	R-1054	THERMOPILE			

USE ONLY MANUFACTURER'S REPLACEMENT PARTS. USE OF ANY OTHER PARTS COULD CAUSE INJURY OR DEATH.

# PARTS VIEW

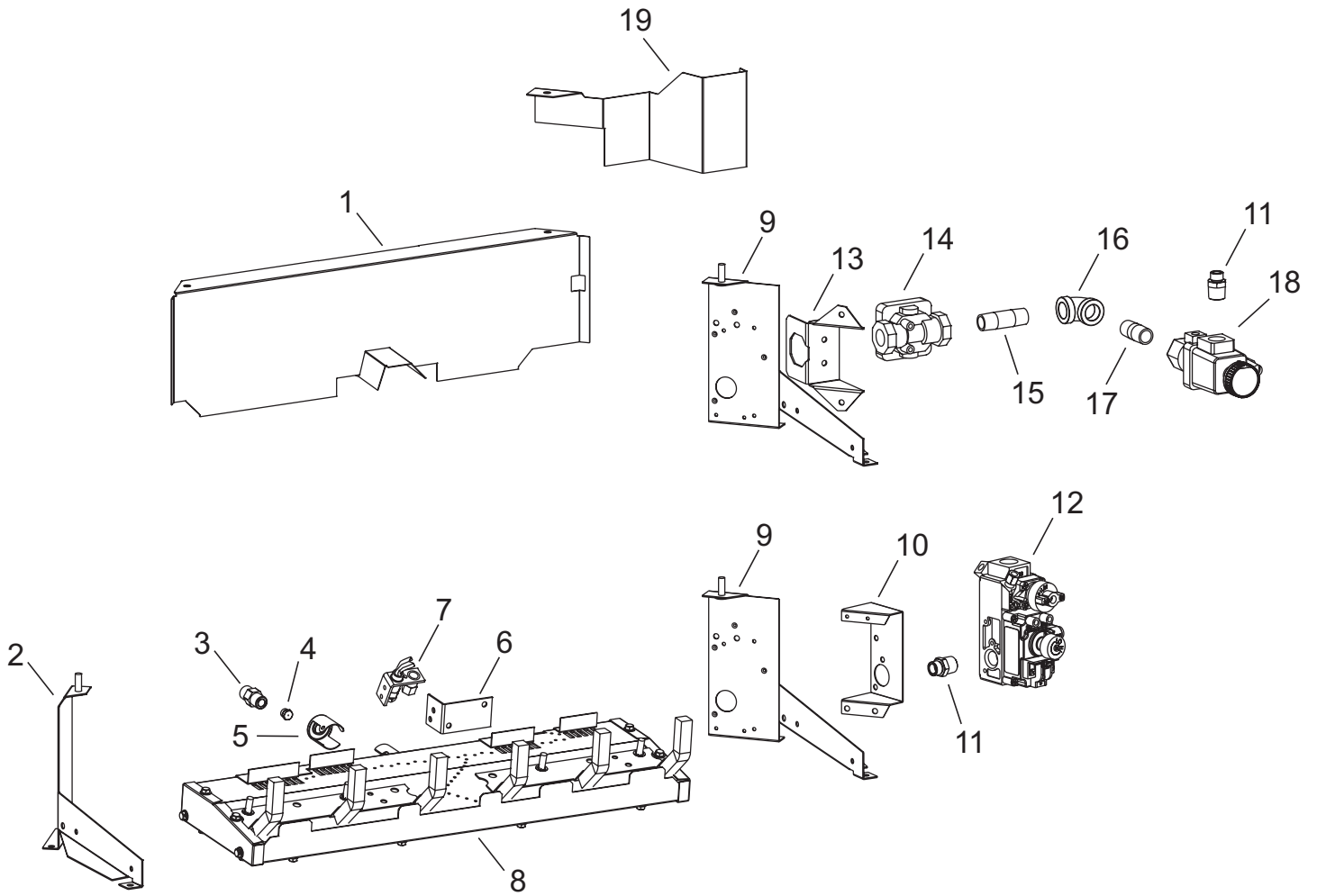

# PROPANE (LP) GAS CONVERSION INSTRUCTIONS

1. If applicable, turn OFF gas supply to vented decorative log set.
2. If applicable, remove gas supply line from vented decorative log set.
3. **For VSM-(18, 24, 30) only**, remove Natural gas inlet regulator from burner assembly.
3. **For VSR-(18, 24, 30) only**, remove regulator cap and blue conversion screw from HI-LO knob on gas valve.
4. **For VSM-(18, 24, 30) only**, install Propane (LP) gas inlet regulator **marked 10.0** onto burner assembly.
4. **For VSR-(18, 24, 30) only**, install Propane (LP) gas **pink conversion screw** into HI-LO knob on gas valve. Assure that conversion screw is finger tight (refer to Honeywell conversion instructions which are included in conversion kit). Install new regulator cap over pink conversion screw.
5. Remove Natural gas main burner orifice from orifice fitting. Save the Natural gas main burner orifice from the appliance for future use.

**Attention:** Use appropriate main burner orifice for **NORMAL** input or **REDUCED** input.

6. Install Propane (LP) gas main burner orifice into orifice fitting for **NORMAL** input.  
**For VSM-18 or VSR-18**, install one Propane (LP) gas main burner orifice **marked 41** for 65,000 BTUH input.  
**For VSM-24 or VSR-24**, install one Propane (LP) gas main burner orifice **marked 40** for 75,000 BTUH input.  
**For VSM-30 or VSR-30**, install one Propane (LP) gas main burner orifice **marked 40** for 75,000 BTUH input.
6. Install Propane (LP) gas main burner orifice into orifice fitting for **REDUCED** input.  
**For VSM-18 or VSR-18**, install one Propane (LP) gas main burner orifice **marked 49** for 40,000 BTUH input.  
**For VSM-24 or VSR-24**, install one Propane (LP) gas main burner orifice **marked 45** for 50,000 BTUH input.  
**For VSM-30 or VSR-30**, install one Propane (LP) gas main burner orifice **marked 43** for 60,000 BTUH input.
7. Remove pilot tubing from pilot burner.
8. Remove Natural gas pilot orifice from pilot burner. Save the Natural gas pilot orifice removed from the appliance for future use.
9. Insert Propane (LP) gas pilot orifice **marked 8** into pilot burner.
10. Attach pilot tubing into pilot burner.
11. Connect gas supply line to vented decorative log set.
12. Attach R-1322, conversion label and R-1321, gas conversion label to the 4 3/4" x 7 1/4" metal plate supplied in conversion kit. Attach 4 3/4" x 7 1/4" metal plate to metal chain which is

attached to base assembly.

## 13. Pressure Testing of the Gas Supply System

- a. To check the inlet pressure to the gas valve, a 1/8" (3mm) N.P.T. plugged tapping, accessible for test gauge connection, must be placed immediately upstream of the gas supply connection to the appliance.
- b. The appliance and its individual shutoff valve must be disconnected from the gas supply piping system during any pressure testing of that system at test pressures in excess of 1/2 psig (3.5 kPa).
- c. The appliance must be isolated from the gas supply piping system by closing its individual manual shutoff valve during any pressure testing of the gas supply piping system at test pressures equal to or less than 1/2 psig (3.5 kPa).

**Attention!** If one of the above procedures results in pressures in excess of 1/2 psig (14" w.c.) (3.5 kPa) on the appliance gas valve, it will result in a hazardous condition.

14. Turn on Propane (LP) gas supply to vented decorative log set.
15. All gas connections must be checked for gas leaks by the person (qualified agency) making the gas conversion. This should be done with a soap solution watching for bubbles on all exposed connections, and if unexposed, a pressure test must be done.
16. Check the appropriate manifold pressure for the vented decorative log set according to **Gas Supply** on Page 8 in this manual.
17. Check pilot burner flame pattern according to **Pilot and Main Burner Flame Characteristics** on Page 12 in this manual.
18. Check main burner flame pattern according to **Pilot and Main Burner Flame Characteristics** on Page 12 in this manual.
19. Gas conversion is completed.

**Attention:** The Propane (LP) gas conversion kit must be ordered from Empire Comfort Systems, Inc.

# NATURAL GAS CONVERSION INSTRUCTIONS

1. If applicable, turn OFF gas supply to vented decorative log set.
  2. If applicable, remove gas supply line from vented decorative log set.
  3. **For VSM-(18, 24, 30) only**, remove Propane gas inlet regulator from burner assembly.
  3. **For VSR-(18, 24, 30) only**, remove regulator cap and pink conversion screw from HI-LO knob on gas valve.
  4. **For VSM-(18, 24, 30) only**, install Natural gas inlet regulator **marked 4.5** onto burner assembly.
  4. **For VSR-(18, 24, 30) only**, install Natural gas **blue conversion screw** into HI-LO knob on gas valve. Assure that conversion screw is finger tight (refer to Honeywell conversion instructions which are included in conversion kit). Install new regulator cap over blue conversion screw.
  5. Remove Propane (LP) main burner orifice from orifice fitting. Save the Propane (LP) gas main burner orifice from the appliance for future use.
- Attention:** Use appropriate main burner orifice for **NORMAL** input or **REDUCED** input.
6. Install Natural gas main burner orifice into orifice fitting for **NORMAL** input.
    - For VSM-18**, install one Natural gas main burner orifice **marked 22** for 65,000 BTUH input.
    - For VSM-24**, install one Natural gas main burner orifice **marked 16** for 75,000 BTUH input.
    - For VSM-30**, install one Natural gas main burner orifice **marked 16** for 75,000 BTUH input.
    - For VSR-18**, install one Natural gas main burner orifice **marked 20** for 65,000 BTUH input.
    - For VSR-24**, install one Natural gas main burner orifice **marked 14** for 75,000 BTUH input.
    - For VSR-30**, install one Natural gas main burner orifice **marked 14** for 75,000 BTUH input.
  6. Install Natural gas main burner orifice into orifice fitting for **REDUCED** input.
    - For VSM-18**, install one Natural gas main burner orifice **marked 32** for 40,000 BTUH input.
    - For VSM-24**, install one Natural gas main burner orifice **marked 28** for 50,000 BTUH input.
    - For VSM-30**, install one Natural gas main burner orifice **marked 24** for 60,000 BTUH input.
    - For VSR-18**, install one Natural gas main burner orifice **marked 31** for 40,000 BTUH input.
    - For VSR-24**, install one Natural gas main burner orifice **marked 29** for 50,000 BTUH input.
    - For VSR-30**, install one Natural gas main burner orifice **marked 26** for 60,000 BTUH input.
  7. Remove pilot tubing from pilot burner.
  8. Remove Propane (LP) gas pilot orifice from pilot burner. Save the Propane (LP) gas pilot orifice removed from the appliance for future use.
  9. Insert Natural gas pilot orifice **marked 12** into pilot burner.
  10. Attach pilot tubing into pilot burner.
  11. Connect gas supply line to vented decorative log set.
  12. Attach R-1322, conversion label and R-1320, gas conversion label to the 4 3/4" x 7 1/4" metal plate supplied in conversion kit. Attach 4 3/4" x 7 1/4" metal plate to metal chain which is attached to base assembly.
  13. **Pressure Testing of the Gas Supply System**
    - a. To check the inlet pressure to the gas valve, a 1/8" (3mm) N.P.T. plugged tapping, accessible for test gauge connection, must be placed immediately upstream of the gas supply connection to the appliance.
    - b. The appliance and its individual shutoff valve must be disconnected from the gas supply piping system during any pressure testing of that system at test pressures in excess of 1/2 psig (3.5 kPa).
    - c. The appliance must be isolated from the gas supply piping system by closing its individual manual shutoff valve during any pressure testing of the gas supply piping system at test pressures equal to or less than 1/2 psig (3.5 kPa).

**Attention!** If one of the above procedures results in pressures in excess of 1/2 psig (14" w.c.) (3.5 kPa) on the appliance gas valve, it will result in a hazardous condition.
  14. Turn on Natural gas supply to vented decorative log set.
  15. All gas connections must be checked for gas leaks by the person (qualified agency) making the gas conversion. This should be done with a soap solution watching for bubbles on all exposed connections, and if unexposed, a pressure test must be done.
  16. Check the appropriate manifold pressure for the vented decorative log set according to **Gas Supply** on Page 8 in this manual.
  17. Check pilot burner flame pattern according to **Pilot and Main Burner Flame Characteristics** on Page 12 in this manual.
  18. Check main burner flame pattern according to **Pilot and Main Burner Flame Characteristics** on Page 12 in this manual.
  19. Gas conversion is completed.
- Attention:** The Natural gas conversion kit must be ordered from Empire Comfort Systems, Inc.

# MASTER PARTS DISTRIBUTOR LIST

To Order Parts Under Warranty, please contact your local Empire dealer. See the dealer locator at [www.empirecomfort.com](http://www.empirecomfort.com). To provide warranty service, your dealer will need your name and address, purchase date and serial number, and the nature of the problem with the unit.

To Order Parts After the Warranty Period, please contact your dealer or one of the Master Parts Distributors listed below. This list changes from time to time. For the current list, please click on the Master Parts button at [www.empirecomfort.com](http://www.empirecomfort.com).

Please note: Master Parts Distributors are independent businesses that stock the most commonly ordered Original Equipment repair parts for Heaters, Grills, and Fireplaces manufactured by Empire Comfort Systems Inc.

## Star-Fire Distributors

1355 Evans Avenue  
Akron, OH 44305

**Phone:** 330-630-2794

**Toll Free:** 800-875-6220

**Fax:** 330-633-8701

**Parts:** Heater & Hearth and Grills

## Dey Distributing

1401 Willow Lake Boulevard  
Vadnais Heights, MN 55101

**Phone:** 651-490-9191

**Toll Free:** 800-397-1339

**Website:** [www.deydistributing.com](http://www.deydistributing.com)

**Parts:** Heater & Hearth

## East Coast Energy Products

10 East Route 36  
West Long Branch, NJ 07764

**Phone:** 732-870-8809

**Toll Free:** 800-755-8809

**Fax:** 732-870-8811

**Website:** [www.eastcoastenergy.com](http://www.eastcoastenergy.com)

**Parts:** Heater & Hearth and Grills

## Victor Division of F. W. Webb Company

200 Locust Street  
Hartford, CT 06114

**Phone:** 860-722-2433

**Toll Free:** 800-243-9360

**Fax:** 860-293-0479

**Toll Free Fax:** 800-274-2004

**Websites:** [www.fwwebb.com](http://www.fwwebb.com) & [www.victormfg.com](http://www.victormfg.com)

**Parts:** Heater & Hearth and Grills

# HOW TO ORDER REPAIR PARTS

## Parts Not Under Warranty

Parts can be ordered through your Service Person, Dealer, or a Master Parts Distributor. See this page for the Master Parts Distributors list. For best results, the **service person or dealer** should order parts through the distributor. Parts can be shipped directly to the **service person/dealer**.

## Warranty Parts

Warranty parts will need a proof of purchase and can be ordered by your Service Person or Dealer. Proof of purchase is **required** for warranty parts.

All parts listed in the Parts List have a Part Number. When ordering parts, first obtain the Model Number and Serial Number from the name plate on your equipment. Then determine the Part Number (**not** the Index Number) and the Description of each part from the following illustration and part list. Be sure to give all this information . . .

Appliance Model Number \_\_\_\_\_ Part Description \_\_\_\_\_

Appliance Serial Number \_\_\_\_\_ Part Number \_\_\_\_\_

Type of Gas (Propane or Natural) \_\_\_\_\_

Do not order bolts, screws, washers or nuts. They are standard hardware items and can be purchased at any local hardware store.

Shipments contingent upon strikes, fires and all causes beyond our control.



Empire Comfort Systems Inc.  
918 Freeburg Ave. Belleville, IL 62220

If you have a general question about our products, please e-mail us at  
[info@empirecomfort.com](mailto:info@empirecomfort.com).

If you have a service or repair question, please contact your dealer.

[www.empirecomfort.com](http://www.empirecomfort.com)